

ACL® CT-Bubble Trap

Clamp Type Bubble Trap



The **CT-Bubble Trap** (Patent Pending) has been developed to incorporate the best features of the ACL Bubble Trap and the CT-SVFI (patent pending). The glass/o-ring/flange end is sealed utilising a sanitary clamp. As there is a mechanical stop, the gasket cannot be over-compressed. The use of a clamp connection reduces the need for tools to assemble or disassemble the bubble trap. Additional seals provide a secondary barrier to prevent the ingress of contaminants to the seal location.



Advantages

- Design is aseptic due to the addition of external o-ring
- Labyrinth design with capillary fluid barriers to halt external media migrating to process side
- Gasket compression is controlled with metal to metal contact
- Assembly / disassembly is very quick and simple
- Minimal screw threads to clean – less COP time
- Force is applied in one direction to the gasket

Applications

- Pharmaceutical processing (chromatography columns)
- Food / dairy
- Chemical processing (seal pot)

Approvals / Compliance

- EC 1935/2004, FDA CFR 21 177.2600 & USP VI <87> <88> Certified gaskets
- Surface finish according to ASME-BPE
- Controlled gasket extrusion to ASME-BPE CAT2
- This product fully complies with the requirements of the European Pressure Equipment Directive 2014/68/EU and carries the 'CE' mark when so required
- Borosilicate glass 3.3 – pressure rating calculated according to CRN (FOS 10:1)

For further information contact:

> PHONE
+44(0)1535 669 216

> FAX
+44 (0)1535 610 243

> EMAIL
sales@advanced-couplings.com

ACL® CT-Bubble Trap

Clamp Type Bubble Trap

Sizing Guide

The most important feature of any bubble trap installation is the selection of the correct size trap. There are two over-riding factors that ultimately dictate which size bubble trap you require:

- **Flow Rate (Q)** - Flow rate of the media entering the bubble trap, measured in litres per minute (LPM).
- **Operating Pressure** - Pressure inside the system when entering the bubble trap.

When these two factors are known a bubble trap can easily be selected from the table below.

Note: ACL stocks a variety of 'CT' sizes from ½" to 8" with variable pressure ratings and fill volumes.

Ratings / Configurations

It should be noted that each separate diameter size of bubble trap overlaps the previous size, this is particularly useful as the small diameter longer length bubble trap will always have a higher pressure rating than its larger sized diameter alternative. The data in the table below is derived from the underlying principal that the media should remain inside the bubble trap for a minimum of 15 seconds (residence time) and is generated from the basic formula:

$$Rt = \frac{Rfv}{Q} \times 60$$

where:

- Rt = Residence Time (greater than 15 seconds)
- Rfv = Recommended Fill Volume (Litres)
- Q = Flow Rate (Litres per minute - LPM)

Note: If your exact flow rate is not shown in the table below, the bubble trap sized for the nearest flow rate larger/quicker than yours must be selected. This will guarantee the residence time will exceed the 15 second minimum.

Bubble Trap Ø (inches)	Rec. Fill Volume (litres)	Flow Rate (LPM)	Operating Pressure		Base Inlet/Outlet Tri-clamp Ferrule Sizes					Lid Controls (2 Ports) Tri-clamp Ferrule Sizes					Lid Controls (3 Ports) Tri-clamp Ferrule Sizes				
			Borosilicate 3.3 Bar (PSI)	Acrylic Bar (PSI)	½"	¾"	1"	1½"	2"	½"	¾"	1"	1½"	2"	½"	¾"	1"	1½"	2"
3"	0.5	2	7.0 (101)	7.5 (109)	•	•				•	•				•	•			
	0.7	3			•	•				•	•				•	•			
	1	4			•	•				•	•				•	•			
4"	1	4	6.0 (87)	7.0 (102)	•	•	•			•	•	•	•		•	•	•		
	2	8			•	•	•			•	•	•	•		•	•	•		
	3	12			•	•	•			•	•	•	•		•	•	•		
6"	2	8	5.5 (80)	6.0 (87)		•	•	•		•	•	•	•	•	•	•	•	•	
	3	12				•	•	•		•	•	•	•	•	•	•	•	•	
	4	16				•	•	•		•	•	•	•	•	•	•	•	•	
	6	24				•	•	•		•	•	•	•	•	•	•	•	•	
	8	32				•	•	•		•	•	•	•	•	•	•	•	•	
8"	6	24	5.0 (73)	5.0 (73)			•	•	•	•	•	•	•	•	•	•	•		
	8	32					•	•	•	•	•	•	•	•	•	•	•		
	10	40					•	•	•	•	•	•	•	•	•	•	•		
	12	48					•	•	•	•	•	•	•	•	•	•	•		
10"	12	48	3.5 (51)	4.0 (58)			•	•	•	•	•	•	•	•	•	•	•	•	
	16	64					•	•	•	•	•	•	•	•	•	•	•	•	
	20	80					•	•	•	•	•	•	•	•	•	•	•	•	

Seal Layout

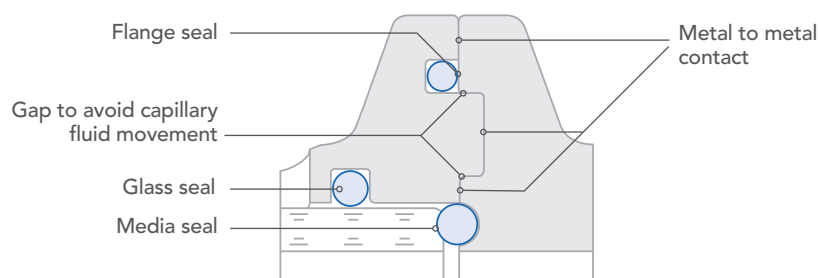

ACL® CT-Bubble Trap

Clamp Type Bubble Trap

Exploded Assembly

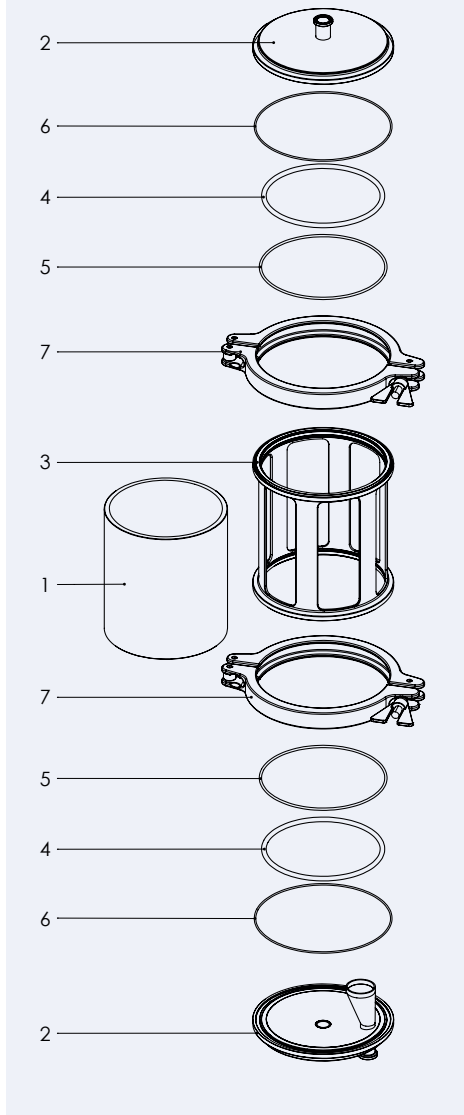

Bill of Materials

Item	Qty	Description	Material	S/Finish - Grade	Available options
1	1	Glass	Borosilicate 3.3	Flame polished	Quartz / Acrylic
2	1	Bubble trap ends	AISI 316L	SF4 - 0.38Ra EP	C22 / AL6XN
3	1	Body	AISI 316L	0.8Ra	C22 / AL6XN
4	2	Sealing o-rings	EPDM	FDA / USP VI	FEP / VITON / PC-SIL
5	2	Cushion o-rings	EPDM	FDA / USP VI	FEP / VITON / PC-SIL
6	2	Clamp o-rings	EPDM	FDA / USP VI	FEP / VITON / PC-SIL
7	2	ACL clamps	CF8M / CF8	0.8Ra	-

Quality Assurance

The ACL Quality Management System is certified according to EN ISO 9001:2015. We ensure that our suppliers also maintain a certified Quality Management System. Materials used in the fabrication of the

CT-Bubble Trap are European sourced and conform to AD2000 W2 and PED. This ensures the highest level of reliability and safety.

Further Information

For detailed selection criteria, technical information, installation guidelines or to contact ACL, please visit our website:

www.advanced-couplings.com

All technical information and advice given here is based on our previous experiences and/or test results. We give this information to the best of our knowledge, but assume no legal responsibility. Customers are asked to check the suitability and usability in the specific application, since the performance of the product can only be judged when all necessary operating data are available. Specifications are subject to change without notice. ACL's terms and conditions of sale apply to the purchase and sale of the product.

Issue 2 - Feb 2020

Advanced Couplings Ltd
 Unit 3A, Riverside Business Park, Royd Ings Avenue, Keighley
 West Yorkshire, BD21 4AF, United Kingdom

T: +44(0)1535 669 216
 F: +44 (0)1535 610 243
 E: sales@advanced-couplings.com